

AC1036 Calibration Kit - Assembly Instructions

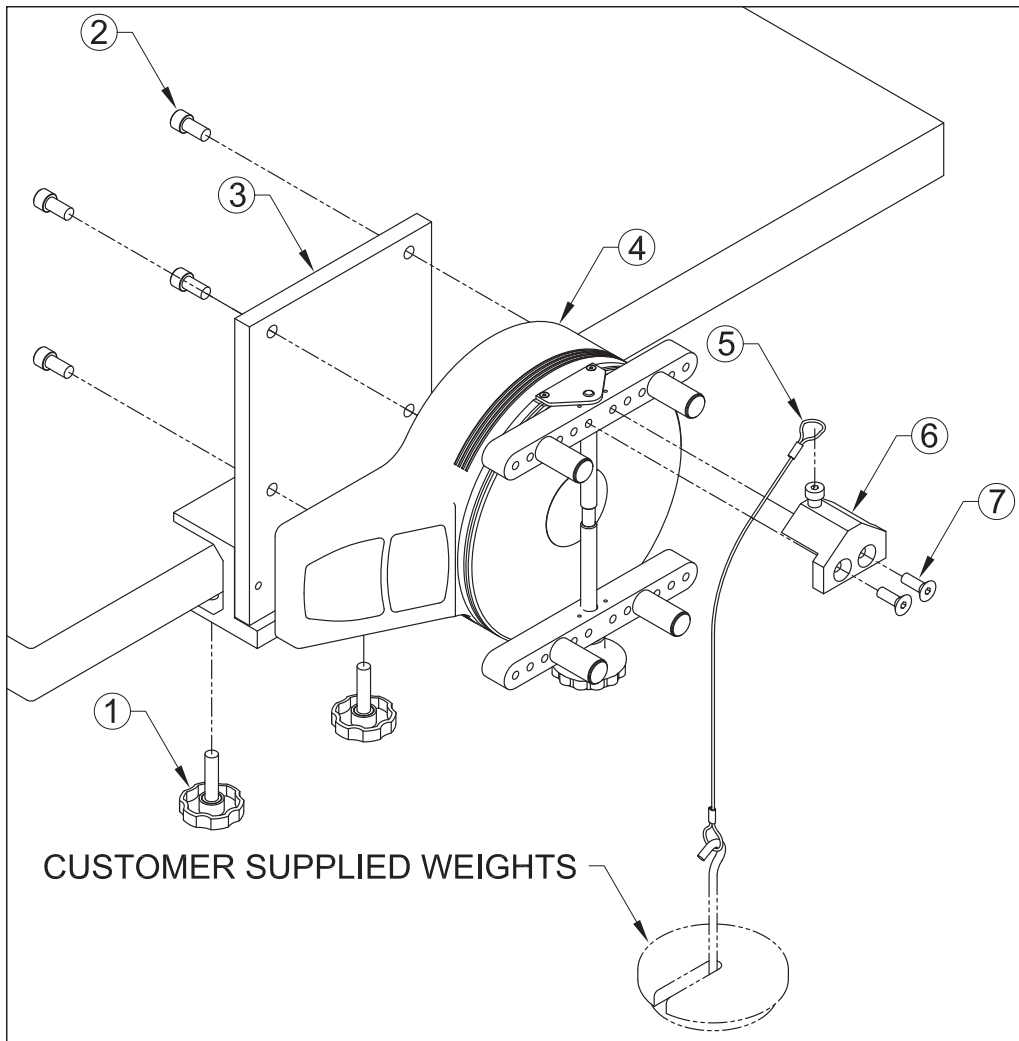

The AC1036 calibration kit is designed to permit the field calibration of any Series TT01 cap torque tester. The kit contains a complete set of attachments required to mount the tester to a bench, as well as the necessary brackets and cable to mount weights. Please note: weights are not available from Mark-10, and must be supplied by the user. The illustration at left depicts proper assembly. Please follow these instructions:

1. Attach the mounting plate / bench mounting bracket assembly (3) to a work bench utilizing the two knob screws (1).
2. Mount the underside of the Series TT01 cap torque tester to the mounting plate utilizing four socket head screws (2). The tester must be oriented with the angled display area to the left.
3. Move the sliders to their outermost positions.
4. Install the cable loop receptacle (6) onto the upper slider by lining up the holes with the two center-most threaded holes in the slider, using two flat head screws (7).
5. Check to ensure that all brackets and screws are properly installed.
6. Place the loop of one end of the cable below the screw head atop the cable loop receptacle. Guide the cable through the groove along the side of the top round plate. Let the end of the cable hang loosely.
7. Hang weights from the loop on the loose end of the cable. Suggested weight configurations are as follows:

<p>MTT01-12: <i>3.6 lb, as follows:</i> 1 lb hanger weight - qty. 1 2 lb slotted weight - qty. 1 0.5 lb weight - qty. 1 0.1 lb weight - qty. 1</p>	<p>MTT01-25: <i>7.5 lb, as follows:</i> 1 lb hanger weight - qty. 1 5 lb slotted weight - qty. 1 1 lb slotted weight - qty. 1 0.5 lb weight - qty. 1</p>
<p>MTT01-50: <i>15 lb, as follows:</i> 1 lb hanger weight - qty. 1 10 lb slotted weight - qty. 1 2 lb slotted weight - qty. 2</p>	<p>MTT01-100: <i>30 lb, as follows:</i> 1 lb hanger weight - qty. 1 20 lb slotted weight - qty. 1 5 lb slotted weight - qty. 1 2 lb slotted weight - qty. 2</p>

8. Refer to the TT01 user's guide for detailed calibration instructions.