

Series **CT**

CLOSURE TORQUE TESTER

User's Guide

MARK-10

Thank you!

Thank you for purchasing a Mark-10 Series CT Torque Tester. We are confident that you will get many years of service from this product.

The CT can be used to test a number of different closure shapes and sizes, along with other types of samples. To maintain normal functioning of the tester, avoid repetitive overloads and shock loads.

We hope that this User's Guide will provide a comprehensive explanation of the CT's operation and sufficient detail on its specifications. However, if you have any other questions or concerns, our technical support and engineering teams will be eager to help you.

Thank you again for your purchase and happy testing!

TABLE OF CONTENTS

UNPACKING AND SETTING UP2

LIST OF INCLUDED ITEMS2

OPTIONAL ITEMS2

CONTROLS.....3

DISPLAY3

POWER4

SETTING UP THE SAMPLE4

CONFIGURATION5

CALIBRATION6

OUTPUTS.....7

SPECIFICATIONS.....8

DIMENSIONS9

WARRANTY9

UNPACKING AND SETTING UP

1. Carefully unpack the CT and check for any damage. Inspect the contents to ensure that you have received a tester complete with all accessories – see “List of included items” below.
2. Place the tester on a firm, flat and level working surface free from vibration. If preferred, the CT can be secured to a work bench with screws through the four tapped holes in the underside of the base. Then insert the posts into the desired holes on the sliders (see Fig. 1).

LIST OF INCLUDED ITEMS

Quantity	Item
1	Series CT Torque Tester
1	User's guide (this booklet)
4	Sample gripping posts
2	Sample gripping jaws (optional)
1	AC adapter

OPTIONAL ITEMS

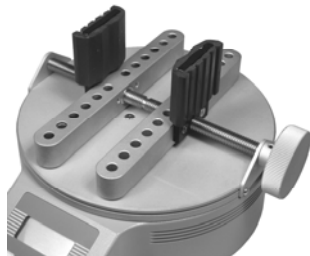

CT001 sample gripping jaws

These jaws are designed for use with square or other shaped containers, in addition to round samples. The jaws are reversible; one side has a V-groove, while the other side is flat. These jaws can be mounted to the inside of the sliders, or the outside.



CTRS data outputs package (RS-232 & Mitutoyo)

This feature allows torque data to be transferred to a PC, printer, or other device for data analysis. The package consists of a serial connector and data button to manually output data. For more automated data collection, common software programs such as WinWedge (available from Mark-10) can be configured to automatically request data from the CT.

CONTROLS

Series CT Torque Testers have four keys for controlling all functions:

POWER	Turns power on and off. Also used to select configuration menu items.
PEAK	Used to select Clockwise Peak, Counterclockwise Peak or Normal (real time) display mode. The actual peak readings are always captured and can be recalled at any time. Also used to step through configuration menu items.
ZERO	Zeros any tare value (up to the full capacity of the gauge) and clears the peak readings stored in memory.
DATA (OPTIONAL)	Used to manually output the torque data point currently displayed.

DISPLAY

The display consists of a 4 1/2-digit section and several indicators. Their functions are listed below.

LO BAT	Low battery voltage indicator
CW	Clockwise torque indicator
CCW	Counterclockwise torque indicator
CW PEAK	Peak clockwise indicator
CCW PEAK	Peak counterclockwise indicator
OZIN, LBIN, NCM, KGMM	Units of measurement (model dependent)
- - - - (dashes)	Overload (>110% of range)

Series CT Closure Torque Testers

POWER

The tester can be operated by the included 9V non-rechargeable battery or by the included AC adapter. Battery life is approximately 30 hours. **Do not use adapters other than supplied or instrument damage may occur.**

There are three levels of low battery voltage indication. At the first level the display shows a steady "LO BAT" indicating approximately one hour of charge remaining. The second level is indicated by a flashing "LO BAT" indicator. At the third level the whole display except the "LO BAT" indicator will flash for three seconds after which time the instrument will turn itself off. This prevents the instrument from working at voltages too low for reliable operation.

To access the battery, loosen the four screws on the bottom plate.

SETTING UP THE SAMPLE

Place the sample between the posts or jaws of the tester, and tighten, using the knob. Posts can be placed in any of the holes on the sliders (see Figs. 1 & 2 below). Ensure that the sample is gripped firmly, however, excessive tightening of thin-walled closures may result in sample deformation, possibly affecting test results. When the sample is secured, **gradually** exert torque by hand. Sudden torque application may produce incorrect readings.



Fig. 1
Posts can easily be moved between holes

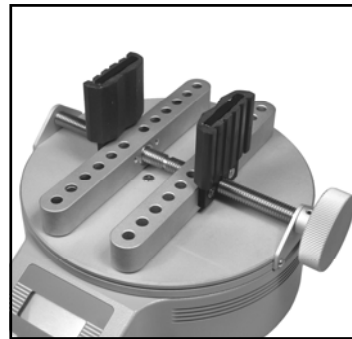

Fig. 2
Optional jaws offer an alternative gripping method

CONFIGURATION

Series CT torque testers have several features with programmable options allowing many user-specified choices. To enter the configuration menu, perform the following:

1. Turn off the tester
2. Press and hold PEAK
3. Turn on the tester
4. Release PEAK

The version number of the internal software will be displayed for a short time followed by either 'AoFF' for a standard CT or '232' if equipped with CTRS communication option. The following secondary functions of keys are used during the configuration process:

POWER Used to select a menu choice
PEAK Used to step through menu choices

NOTE: Once the menu has been entered, it can only be exited if changes have been made.

The following list shows all configuration options. *Italics* indicate factory settings.

232 - RS-232 settings sub-menu

232d	Output Disabled
232E	Output Enabled
300	300 baud
600	600 baud
1200	1200 baud
2400	2400 baud
4800	4800 baud
9600	9600 baud
7-1E	7 data bits, 1 stop bit, even parity
7-1o	7 data bits, 1 stop bit, odd parity
7-2E	7 data bits, 2 stop bits, even parity
7-2o	7 data bits, 2 stop bits, odd parity
7-2n	7 data bits, 2 stop bits, no parity
8-1E	8 data bits, 1 stop bit, even parity
8-1o	8 data bits, 1 stop bit, odd parity
8-1n	8 data bits, 1 stop bit, no parity
8-2n	8 data bits, 2 stop bits, no parity
Ft F	Full data (numeric + units)
Ft n	Numeric data only

bcd - Mitutoyo BCD settings sub-menu

bccd	Output disabled
bcdE	Output enabled

Series CT Closure Torque Testers

AoFF - Automatic shutoff settings sub-menu

no	Disabled
1	1-minute automatic shutoff
5	5-minute " "
10	10-minute " "
20	20-minute " "
30	30-minute " "

init - Initial (default) settings sub-menu

LBIN	Pound-inch as default unit
KGMM	Kilogram-millimeter " "
NCM	Newton-centimeter " "
CCW	Real time display at turn on
PEAK CW	Peak clockwise display at turn on
PEAK CCW	Peak counterclockwise display at turn on

CAL - Calibration sub-menu. See CALIBRATION section.

CALIBRATION

To properly calibrate the CT, application of a precise torque value equal to the full capacity of the tester in lbin (regardless of the displayed units) will be required.

While holding PEAK, turn on power to the tester. When 'CAL' appears on the display, press POWER three times to select the calibration mode. At the 'null' prompt, press ZERO. At the 'SPAN' prompt, apply the calibration torque and press POWER. The display will show 'uuuu' or 'nnnn' if the calibration torque is insufficient or excessive, respectively. If this happens, the only way to terminate the calibration mode is by momentarily disconnecting the battery or connecting the AC adapter to the tester without plugging the other end into a wall outlet. This will stop the calibration procedure without making any changes to the previous calibration data.

Successful calibration is indicated by 'donE' on the display. Press POWER to save the changes and resume normal operation.

OUTPUTS

Outputs are available as part of the CTRS communication option. If installed, it offers RS-232 and Mitutoyo BCD outputs on the 9-pin male connector. Please refer to the pin diagram below for proper connection.

RS-232

The data transmission can be initiated by pressing the DATA button or by an external device by sending ASCII "?" to the gauge. The gauge will respond by sending the current reading in either full or numeric format, depending on the configuration setting (see Section 3). Polarity sign indicates CW (+) or CCW (-) torque. The transmitted string has the following format:

[POLARITY (SPACE OR -)][DATA][SPACE][UNITS (IF ENABLED)][CRLF]

Mitutoyo BCD

This output is useful for connection to data collectors, printers, multiplexers or any other device capable of accepting Mitutoyo BCD data. The transmission is initiated by the DATA button (see Section 3 about settings) or by the receiving device.

I/O connector pin diagram

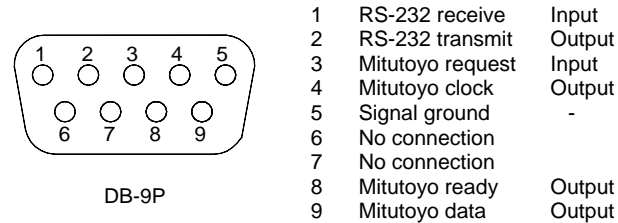

Series CT Closure Torque Testers

SPECIFICATIONS

Accuracy:	±0.5% of full scale ±1 digit
Sampling rate:	30/s
Display update rate:	2.5/s in normal mode, 30/s in peak mode
Safe overload:	150% of gauge capacity. Display shows ---- (dashes) above 110%.
Outputs (optional):	
RS-232:	Baud rates between 300 and 9600
Mitutoyo:	Standard Mitutoyo BCD output
Connector:	9-pin D-type male
Power:	9V battery or AC adapter
Battery life:	30 hours of continuous operation
Weight:	10 lb [4.5 kg]
Capacity x resolution:	
CT12	12 x 0.01 lbFin, 140 x 0.1 kgFmm, 135 x 0.1 Ncm
CT50	50 x 0.05 lbFin, 580 x 0.5 kgFmm, 570 x 0.5 Ncm
CT100	100 x 0.1 lbFin, 1150 x 1 kgFmm, 1150 x 1 Ncm

DIMENSIONS

in [mm]

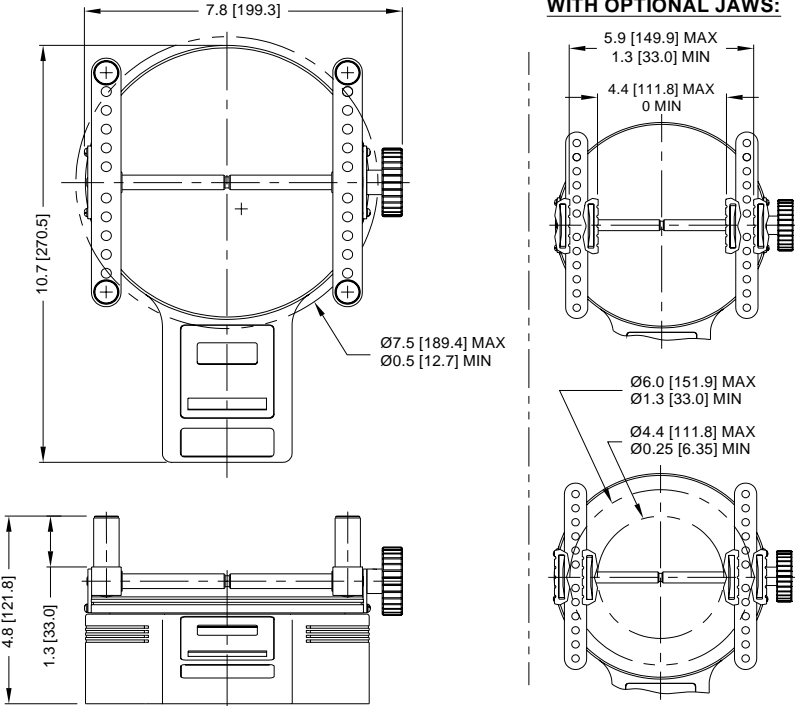

WARRANTY

Mark-10 Corporation expressly warrants to its buyer for three (3) years from the date of delivery that the goods sold are free from defects in workmanship and materials. Mark-10 Corporation will, at its option, repair or replace or refund the purchase price of goods found to be defective. This remedy shall be the buyer's sole and exclusive remedy. Any modification, abuse, exposure to corrosive environment or use other than intended will void this warranty. This warranty is in lieu of all other warranties, including implied warranties of merchantability and fitness for an intended purpose. In no event shall Mark-10 Corporation be liable for any incidental and consequential damages in connection with goods sold or any part thereof.



Mark-10 Corporation has been an innovator in the force and torque measurement fields since 1979. We strive to achieve 100% customer satisfaction through excellence in product design, manufacturing and customer support. In addition to our standard line of products we can provide modifications and custom designs for OEM applications. Our engineering team is eager to satisfy any special requirements. Please contact us for further information or suggestions for improvement.

MARK-10

We make a measurable difference in force and torque measurement

Mark-10 Corporation

11 Dixon Avenue
Copiague, NY 11726 USA
1-888-MARK-TEN
Tel: 631-842-9200
Fax: 631-842-9201
Internet: www.mark-10.com
Email: info@mark-10.com

32-1039
01/08
REV 2