

Force Test Stands Series **ES**

MODEL ESM300

User's Guide

MARK-10

Thank you...

Thank you for purchasing a Mark-10 ESM300 Programmable Force Test Stand, designed for producing up to 300 lbF (1.5 kN) of tension or compression force. The ESM300 is an essential component of a force testing system, typically also comprising a force gauge, and grips or fixtures to secure the test sample.

With proper usage, we are confident that you will get many years of great service with this product. Mark-10 test stands are ruggedly built for many years of service in laboratory and industrial environments.

This User's Guide provides setup, safety, and operation instructions. Dimensions and specifications are also provided. For additional information or answers to your questions, please do not hesitate to contact us. Our technical support and engineering teams are eager to assist you.

Before use, each person who is to use the ESM300 should be fully trained in appropriate operation and safety procedures.

TABLE OF CONTENTS

LIST OF INCLUDED ITEMS	2
OVERVIEW	2
MECHANICAL SETUP AND SAFETY	2
OPERATION BASICS	7
TEST PARAMETER SETUP	9
OPERATING MODES	17
FEATURE ENABLING SETUP	22
MAINTENANCE AND SERVICE	24
SPECIFICATIONS	26
DIMENSIONS	26

1 LIST OF INCLUDED ITEMS

Qty.	Item
1	ESM300 test stand
4	Force gauge mounting screw
1	User's guide (this booklet)
1	Power cord
1	Cable, controller to test frame, 6"
1	Accessories kit (small hook, medium hook, 2" diameter compression plate, 2" extension rod, #10-32 coupler, tool kit)
1	Digital travel display kit (optional)
1	Column extension (optional)

2 OVERVIEW

The ESM300 has three functional modes:

1. OPERATING MODE

This is the operating mode in which testing sequences can be started and stopped.

2. TEST PARAMETER SETUP

In this mode, test parameters are configured, such as rate of speed, number of cycles, password editing, and other parameters.

3. FEATURE ENABLING SETUP

This facility allows the user to enable features not originally purchased through a code activation process.

3 MECHANICAL SETUP & SAFETY

3.1 Appropriate Test Samples

Typical materials able to be tested by the ESM300 include many manufactured items, such as springs, electronic components, fas-

teners, caps, films, mechanical assemblies, and many others. Items that should not be used with the ESM300 include potentially flammable substances or products, items that can shatter in an unsafe manner, and any other components that can present an exceedingly hazardous situation when acted upon by a force.

3.2 Using Grips & Fixtures With The ESM300

Ensure that the grip or fixture is positioned to ensure axial load with respect to the loading shaft of the force gauge. Failure to do so may put sideways pressure on the sample, possibly causing it to slip out during testing. This poses a potential safety risk to the operator and others in the vicinity. When using a grip, ensure that it secures the sample in such a way that it is prevented from slipping out during a test. If using a grip or fixture from a supplier other than Mark-10, ensure that it is constructed of suitably rugged materials and components.

3.3 Mounting

Place the stand on a clean, flat and level work area free from vibration. If desired, the stand can be secured to the work area with 1/4-20 screws fastened into the underside of the base. Failure to properly mount the test stand may make it more vulnerable to tipping, causing a hazardous situation.

IMPORTANT: Do not fasten any screws more than 0.25 in [6 mm] into the base of the test stand, or damage to internal components can occur.

In general, the ESM300 can be mounted at any angle, although extra care should be taken during installation and operation.

Once the test stand is in a stable and secure position, install a force gauge with four thumb screws (provided). All Mark-10 gauges (except the Series CG) mount directly without adapters. Grips can be mounted onto the force gauge and test stand base. If an optional digital travel display was ordered, it will be installed in the factory before shipping.

The following illustration highlights the major components of a force testing system:



3.4 Setting Up The Controller

The power plug and controller cable must be connected to the rear of the controller, as shown in the illustration below:

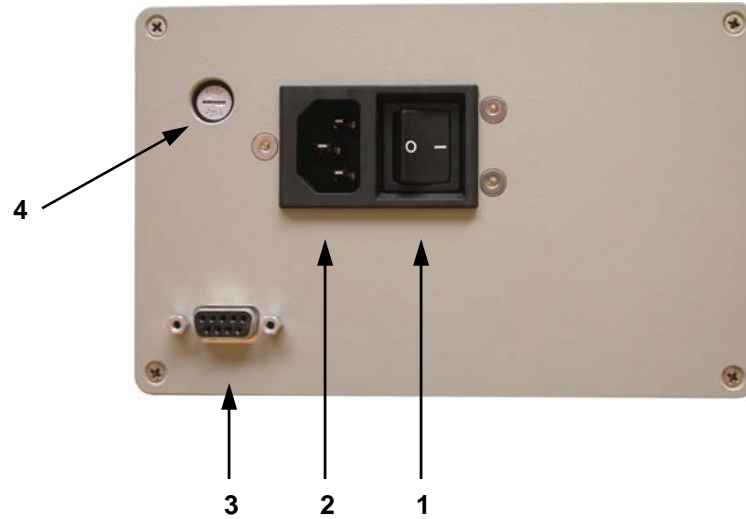

1. Power Switch

Use this switch to turn on and turn off power to the test stand. Power is indicated by an amber light on the front of the Control Unit.

2. Power Plug Receptacle

Plug the power cord in here.

3. Controller Cable Connector

Plug one end of the cable into this connector, and the other end into the connector as shown in the illustration on the following page.

4. Fuse

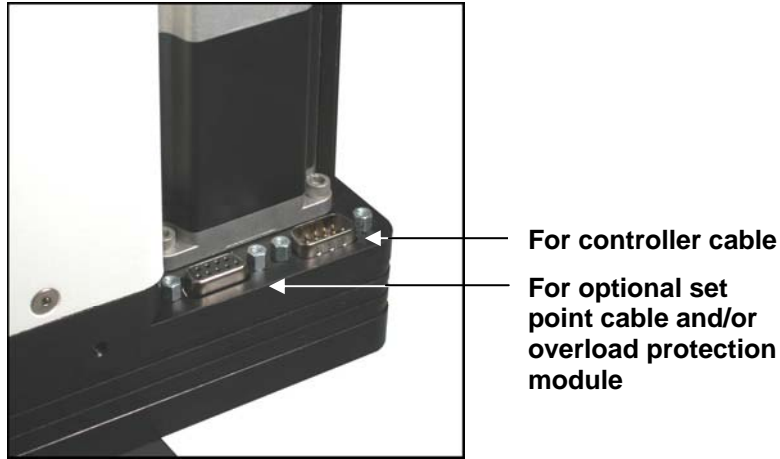

3.5 Connecting Power

Plug one end of the power cord into its receptacle at the rear of the controller and the other end into a wall outlet with local earth ground (3-prong connector).

Before turning on power, the following safety checks and procedures should be performed:

1. Never operate the test stand if there is any visible damage to the power cord or the test stand itself. The ESM300 is powered by 110V/220V. Any contact with this high voltage can cause serious injury or even death.
2. Ensure that the test stand is kept away from water or any other electrically conductive liquids at all times.
3. Make sure the electrical outlet powering the test stand has local earth ground (3-prong connector).
4. The test stand should be serviced by a trained technician only. Power must be disconnected before the controller is opened.

After the above safety checks and procedures have been performed, the test stand may be powered on and is ready for operation.

4 OPERATION BASICS

4.1 Operational Safety

The following safety checks and procedures should be performed before and during operation:

1. Always consider the characteristics of the sample being tested before initiating a test. A risk assessment should be carried out beforehand to ensure that all safety measures have been addressed and implemented.
2. Wear eye and face protection when testing, especially when testing brittle samples that have the potential to shatter under force. Although the ESM300 has relatively slow moving mechanisms, be aware of the dangers posed by potential energy that can accumulate in the sample during testing. Extra bodily protection should be worn if a destructive failure of a test sample is possible.
3. Keep away from moving parts of the test stand. Loose articles of clothing should not be worn, and long hair should be covered to avoid being caught in any moving parts. A Crush Hazard warning label is located on the base of the test stand. It appears as follows:



Definition: Keep any body parts and clothing clear of the area between the base of the test stand and the moving crosshead.

4. In certain applications, such as the testing of brittle samples that can shatter, or other applications that could lead to a hazardous situation, it is strongly recommended that a machine guarding system be employed to protect the operator and others in the vicinity from shards or debris.
5. When the test stand is not in use, ensure that the power is turned off to prevent accidental engagement of any of the controls.

4.2 Controls Layout

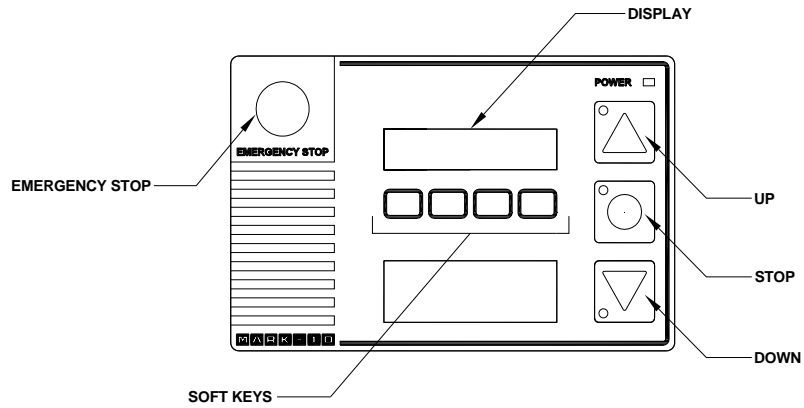

SOFT KEYS	Functions are determined by the corresponding text on the display.
UP	Commences movement in the up direction.
DOWN	Commences movement in the down direction.
STOP	Stops crosshead movement.
EMERGENCY STOP	Stops crosshead movement and disables the test stand until reset.

5 TEST PARAMETER SETUP

This section provides configuration instructions for each test parameter. Parameters include:

Parameter	Standard / Optional
Units of speed selection	Standard
Speed (same for both directions)	Standard
Password configuration	Standard
Independent up and down speeds	Optional
Auto return	Optional
Cycling with dwell time	Optional
Programmable button configuration	Optional

Only installed features will be displayed in Test Parameter Setup. The initial Test Parameter Setup screen appears as follows:

```

UNITS:          in/min
ESC  < - - >  ENTR
    
```



ESC	Exits Test Parameter Setup, reverts to Operating Mode
< -	Scrolls to the previous parameter
- >	Scrolls to the next parameter
ENTR	Selects the parameter, allowing it to be modified

When the parameters have been configured as desired and are ready to be saved, press **ESC** to exit Test Parameter Setup. The screen will show **SAVE CHANGES?** Pressing **YES** will save the changes and the display will revert to current status. Pressing **NO** will not save the changes and return to the Test Parameter Setup menu.

Note: Changes can be made to an unlimited number of settings before saving.

Below is a flow chart for the menu structure. For details on each specific parameter, refer to the following pages.

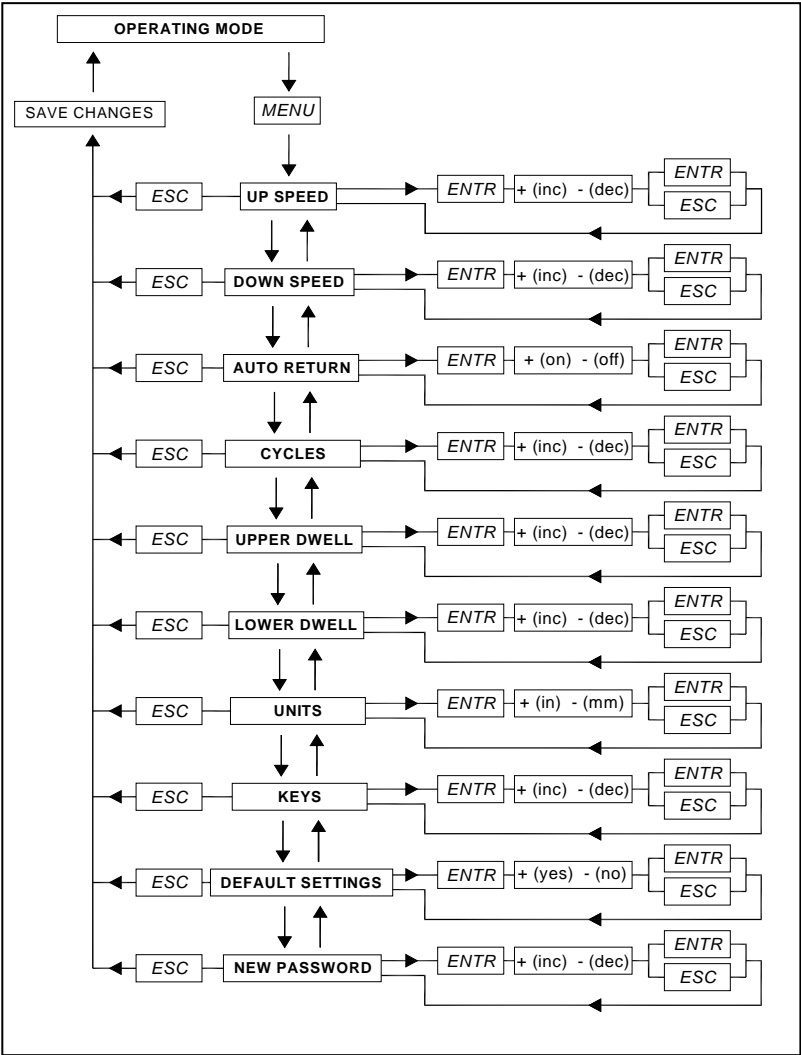

5.1 Units of Speed Measurement (UNITS)

Default setting: in/min

Available settings: in/min, mm/min

UNITS:			mm/min
ESC	-	+	ENTR



+ or -	Changes speed units between in/min and mm/min
ENTR	Returns to the Test Parameter Setup menu
ESC	Exits the parameter without saving changes

5.2 Speed, Up Speed, Down Speed (SPEED, UP SPEED, DN SPEED)

Three speed settings are available. If the up and down speeds are to be the same, only the **SPEED** setting needs to be programmed. If independent up and down speeds are desired, program the **UP SPEED** and **DN SPEED** settings individually.

Default setting: 10 in/min or 250 mm/min

Available settings: 0.02 – 45 in/min or 0.5 – 1100 mm/min

UP SPEED:			10.73
ESC	-	+	ENTR



+	Increments the speed setting by .01 in or .1 mm. Holding down + will increment at an increasingly faster rate.
-	Decrements the speed setting by .01 in or .1 mm. Holding down - will decrement at an increasingly faster rate.
ENTR	Returns to the Test Parameter Setup menu
ESC	Exits the parameter without saving changes

5.3 Auto Return (AUTO RETURN)

With this feature, the crosshead moves to a limit switch or force set point (applicable to Mark-10 force gauges with set point outputs), stops, returns to the other limit switch or set point, and stops. The speed at which the crosshead travels to the limit switch or set point is dictated by the **SPEED**, **UP SPEED**, or **DN SPEED** setting. The speed at which the crosshead returns to the other limit switch or set point is always maximum speed.

Default setting: off

Available settings: off, on

AUTO RETURN:	off
ESC	- + ENTR



+ or -	Changes auto return setting between on and off
ENTR	Returns to the Test Parameter Setup menu
ESC	Exits the parameter without saving changes

Note: If **AUTO RETURN** is turned **on**, **CYCLING** is automatically turned **off** and the **KEYS** parameter is automatically set to **MAINTAINED** mode. See following pages for details on **CYCLING** and **KEYS** parameters.

5.4 Default Settings (DEFAULT?)

This setting provides a quick return to factory settings, as follows:

UNITS:	in/min
SPEED:	10 in/min
UP SPEED:	10 in/min
DN SPEED:	10 in/min
AUTO RETURN:	off
PASSWORD:	0000 (off)
KEYS:	maintained
CYCLING:	off

Default setting: off
Available settings: off, on

DEFAULT?:	NO
ESC	- + ENTR



+ or -	Changes default settings selection between YES and NO
ENTR	Returns to the Test Parameter Setup menu
ESC	Exits the parameter without saving changes

5.5 Password (NEW PWORD)

If desired, a password can be set to prevent unwanted changes to test parameters. The password can be set to any number between 0000 and 9999. The default setting of 0000 indicates that the password is disabled, and that the user can freely enter the Test Parameter Setup menu.

Default setting: 0000 (off)
Available settings: 0000 – 9999

NEW PWORD:	0000
ESC	- + ENTR



+	Increases the number in increments of 1. Holding down + will increment at an increasingly faster rate. If 9999 is reached the next number will be 0000 and continue incrementing.
-	Decreases the number in increments of 1. Holding down - will decrement at an increasingly faster rate. If 0000 is reached the next number will be 9999 and continue decrementing.
ENTR	Returns to the Test Parameter Setup menu
ESC	Exits the parameter without saving changes

5.6 Programmable Button Function (KEYS)

Three button function modes are available:

1. **Maintained**
The crosshead will move continuously once the button has been pressed. Subsequently pressing the **UP**, **DOWN**, or **STOP** during a test will stop crosshead motion.
2. **Momentary**
The crosshead will move only if the button is held down. Releasing the button will stop movement immediately.
3. **Auto**
Holding down the button for more than 0.5 seconds will enter momentary mode, at which time an audible indicator will sound and the LED indicator on the button pushed will be illuminated. A short tap on the button will operate the test stand in maintained mode. Pressing **UP**, **DOWN**, or **STOP** during maintained mode will stop crosshead motion.

Default setting: maintained

Available settings: maintained, momentary, auto

KEYS:	m a i n t a i n e d			
ESC	-	+	ENTR	



+ or -	Changes key setting between maintained, momentary, and auto
ENTR	Returns to the Test Parameter Setup menu
ESC	Exits the parameter without saving changes

5.7 Cycling (CYCLES)

This setting allows the user to configure the number of up and down cycles through which the crosshead will sequence. One cycle consists of the crosshead moving to a limit switch or force set point (applicable to Mark-10 force gauges with set point outputs), at the specified speed, stopping for the specified amount of dwell time, and returning to the other limit switch or set point at the specified speed.

Default setting: 00000 (off)

Available settings: 00000 – 99999

CYCLES:	0 0 0 0 0			
ESC	-	+	ENTR	



+	Increases the number of cycles in increments of 1. Holding down + will increment at an increasingly faster rate. If 99999 is reached the next number will be 00000 and continue incrementing.
-	Decreases the number of cycles in increments of 1. Holding down - will decrement at an increasingly faster rate. If 00000 is reached the next number will be 99999 and continue decrementing.
Press and hold + and - simultaneously	If pressed and held for 2 seconds or longer the number of cycles will change to 0.
ENTR	Returns to the Test Parameter Setup menu
ESC	Exits the parameter without saving changes

5.8 Upper Limit Dwell Time and Lower Limit Dwell Time (DWELL U and DWELL L)

This setting corresponds to the amount of time, in seconds, for which the crosshead stops at the limit switch or force set point during a cycle sequence

Note: the dwell time setting is unavailable for an auto return sequence.

Default setting: 0 (no dwell time)

Available settings: 0 – 9999.9

DWELL U:	0 0 0 0 . 0
ESC	- + ENTR



+	Increases dwell time in increments of .1. Holding down + will increment at an increasingly faster rate. If 9999.9 is reached the next number will be 0 and continue incrementing.
-	Decreases dwell time in increments of .1. Holding down - will decrement at an increasingly faster rate. If 0 is reached the next number will be 9999.9 and continue decrementing.
ENTR	Returns to the Test Parameter Setup menu
ESC	Exits the parameter without saving changes

6 OPERATING MODES

The ESM300 can be operated in three modes:

1. **Basic Mode**
Manual control of crosshead motion.
2. **Auto Return Mode**
Crosshead moves to a limit switch or force set point, then reverses and moves at full speed to the other limit switch or set point.
3. **Cycling Mode**
Crosshead cycles between limit switches or force set points at the selected speed, and pauses at each limit or set point for a selected period of time.

The Operating Mode screen appears as follows:

Speed:	0.00
menu min max SET	



menu	Enters Test Parameter Setup
min	Sets speed to minimum speed
max	Sets speed to maximum speed
set	Sets speed to the programmed SPEED, UP SPEED, or DN SPEED setting

The item selected will be capitalized, as shown in the figure above. The **set** speed can be changed in Test Parameter Setup. If enabled, the up and down speeds can be configured independently of each other (**UP SPEED** and **DN SPEED**). Otherwise, the **SPEED** setting corresponds to crosshead speed in both directions.

6.1 Menu Navigation

At power-up, the display will show the operation screen for either Basic Mode, Auto Return Mode, or Cycling Mode, whichever was used last. The travel speed or number of cycles is displayed, along with text corresponding to the four soft key buttons. The display will appear as one of the following:

Basic & Auto Return Modes:

```
Speed:          0.00
menu min max SET
```



Cycling Mode:

```
CYCLES:        00024
menu min max SET
```



OR

Pressing **menu** will enter Test Parameter Setup. If password protection is enabled, the display will prompt the following:

```
P A S S W O R D :    0 0 0 0
ESC  +   ->  ENTR
```



The password is a four digit number. The first digit in the password will be flashing, signifying that it is active and can be incremented by pressing **+**. To advance to the next digit, press **->**. Change the subsequent digits in the same fashion. Once the complete pass-

word has been entered, press **ENTR**. If correct, the display will show the Test Parameter Setup. If the password is incorrect, the words **INCORRECT PASSWORD** will flash, and the display will revert to Operating Mode.

6.2 Basic Mode

The crosshead moves upward when **UP** is pressed, and downward when **DOWN** is pressed. When the crosshead is in motion, an LED indicator on the button pushed will be illuminated. The **KEYS** setting controls how crosshead movement corresponds to the buttons. The three settings are:

1. **Maintained (default)**

The crosshead will move continuously once the button has been pressed. Subsequently pressing **STOP** during a test will stop crosshead motion.

2. **Momentary**

The crosshead will move only if the button is held down. Releasing the button will stop movement immediately.

3. **Auto**

Holding down the button for more than approximately 0.5 seconds will enter momentary mode, at which time an audible indicator will sound and the LED indicator on the button pushed will be illuminated. A short tap on the button will operate the test stand in maintained mode. Pressing **STOP** during maintained mode will stop crosshead motion. To resume the test, press **UP** or **DOWN** again.

In an emergency situation, press the **EMERGENCY STOP** button. To release the button, twist it counter-clockwise until it assumes its original position. To resume the test, press **UP** or **DOWN** again.

Limit Switch Operation

Limit switches allow the operator to set a location along the column at which point the crosshead will stop moving. Limit switches are located at the rear of the test stand column. Adjust the switches'

positions by loosening, repositioning, and re-tightening the thumb screws.

Note: the distance between limit switches must be at least 0.2 in [5 mm].

6.3 Auto Return Mode

With this setting, the crosshead moves to a limit switch or force set point (applicable to Mark-10 force gauges with set point outputs), stops, returns to the other limit switch or set point, and stops. The speed at which the crosshead travels is dictated by the **SPEED** or **UP SPEED** and **DN SPEED** settings (if enabled). Press **UP** or **DOWN** to initiate an Auto Return sequence.

The crosshead can be stopped at any time during an Auto Return sequence by pressing **STOP**. To resume the test, press **UP** or **DOWN** again.

As in Basic Mode, crosshead speed is displayed in the upper right of the indicator, and the **min**, **max**, and **set** soft keys are active.

6.4 Cycling Mode

This mode cycles the crosshead between limit switches or force set points (applicable to Mark-10 force gauges with set point outputs). One cycle consists of the following steps:

1. Crosshead moves to a limit switch or force set point, at the specified speed.
2. Crosshead stops for the specified amount of dwell time.
3. Crosshead reverses direction, returns to the other limit switch or set point at the specified speed, and stops.

A cycling sequence can be initiated from any position and can start in either direction. If the crosshead is at a limit switch or force set point, however, cycling can only be started in the direction of the other limit switch or force set point. To initiate a cycle sequence, press **UP** or **DOWN**. During a cycle sequence, a counter will be displayed, indicating the number of cycles remaining in the sequence, as shown below:

CYCLES:	0	0	2	4
menu	min	max	SET	



As in Basic Mode, the **min**, **max**, and **set** soft keys are active during crosshead movement.

Dwell time

Dwell time is the amount of time, in seconds, for which the crosshead stops at the limit switch or force set point during a cycle sequence. When the crosshead has reached a limit switch or force set point, a dwell time counter will be displayed, as shown below:

DWELL:	0	0	1	.5
menu	min	max	SET	



If the **DWELL U** and/or **DWELL L** settings are set to 0, the crosshead will immediately reverse direction upon reaching the corresponding limit switch or force set point, and no counter will be displayed.

The cycle sequence may be interrupted before it has been completed by pressing **STOP**. A soft key labeled **RESET** will appear as follows:

CYCLES:	0	0	2	4
			RESET	



At this point, there are two options:

1. **Canceling the cycle sequence:**
Pressing **RESET** will stop and reset the cycle sequence. The cycle counter will revert to the number of cycles originally programmed.
2. **Resuming the cycle sequence:**
Press **UP** or **DOWN** to resume.

Once the sequence has been completed, the screen will revert to the number of cycles programmed originally. To begin another cycle test, press **UP** or **DOWN**.

7 FEATURE ENABLING SETUP

This menu displays the features that are enabled and disabled. Those that are disabled can be enabled by purchasing them. Features that are enabled are indicated by **ON**, and those that are disabled are indicated by **OFF**.

7.1 Accessing Feature Enabling Menu

While in Operating Mode, press and hold **STOP** and **menu** simultaneously. Then, release **STOP** and **menu**.

The display will appear as follows:

KEYS:	OFF
ESC	<- -> ENTR



<-	Scrolls to the previous parameter
->	Scrolls to the next parameter
ENTR	Selects the feature
ESC	Exits Feature Enabling Setup menu

The Feature Enabling Menu also includes a utility with which to re-set the password. To reset the password, scroll through the features until the following is displayed:

CLEAR PASSWORD?			
ESC	<-	->	ENTR



Press **ENTR** to clear the password, or **ESC** to re-enter the menu.

7.2 Enabling Features

Features not originally purchased can be enabled with an *authorization code*. To enable the feature, scroll through the menu until the desired feature is displayed, then press **ENTR**. If the feature is already enabled (indicated by **on**), pressing **ENTR** has no effect. If the feature is off, pressing **ENTR** will bring up a *request code* on the display. An example is shown below:

KEYS:	0	1	3	9	0	2	7
ESC	+	->	ENTR				



The *request code* must be supplied to Mark-10 or a distributor, who will then provide a corresponding *authorization code*.

The process for entering the *authorization code* is as follows:

1. The first digit of the *request code* will be flashing. Press **+** to increment the digit. Pressing **+** when the number 9 is displayed will return to 0.
2. Press **->** to advance to subsequent digits, and change them in the same fashion.

3. Press ENTR to enable the feature. If an incorrect code is entered, the controller will return to the Feature Enabling Setup menu, without enabling the feature. If this happens the above process must be repeated.

Note: the *request code* is randomly generated. Accordingly, an *authorization code* can be used only for its corresponding feature.

7.3 Demo Mode

All ESM300 test stands are shipped in *Demo Mode*, which provides full functionality of all available features for an evaluation period of 160 operating hours. *Demo Mode* can be disabled by pressing and holding **STOP** while turning on power to the test stand. This mode can be re-enabled in the same fashion, and will be active for the remaining number of hours.

8 MAINTENANCE AND SERVICE

The ESM300 should be operated in a dry and clean area. Under these circumstances only a few periodic maintenance operations are required:

1. Acme screw lubrication – twice per year

1. Remove the right column cover by loosening the screws, as shown in the following illustration:



2. Using a brush, apply a small amount of silicon-based grease to the lead screw.
3. Cycle the crosshead up and down several times until the newly applied grease has been spread evenly over the length of the screw. Re-install the column cover.

2. Check for loosened grips and attachments - daily

Check to ensure that the grips attached to the force gauge and base plate are firmly secured. Looseness could result in a potentially hazardous situation.

3. Check for loosened components – once per month

1. Remove the test sample from the test stand.
2. Turn off power to the test stand and disconnect the power cord. Attempt to loosen subcomponents of the test stand (ex. fasteners, brackets, etc). All components should be firmly attached. If any looseness is detected, stop using the test stand and contact Mark-10 or a distributor for instructions.

9 SPECIFICATIONS

Load capacity	
Up to 24 in/min (610 mm/min)	300 lbF [1.5 kN]
> 24 in/min (> 610 mm/min)	200 lbF [1 kN]
Standard speed range	0.5-13 in/min [13-330 mm/min]
Maximum travel	12.5 in [317 mm]
Speed setting accuracy	±0.2%
Speed variation with load	±0% [Stepper motor driven]
Limit switch repeatability	0.001 in [0.03 mm]
Power	Universal input 80-240 VAC, 50/60 Hz
Weight (without options)	30 lbs [13.6 kg]
Power	Universal input 80-240 VAC, 50/60 Hz
Fuse type	1.2 A, 250V, 3AG SLO BLO
Included accessories:	Extension rod, small hook, medium hook, #10-32 coupler, compression plate, force gauge mounting hardware, tool kit

10 DIMENSIONS

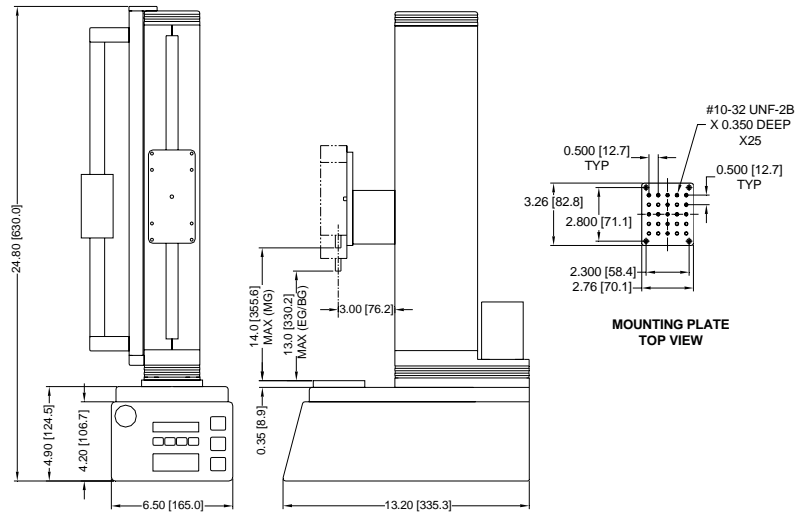



Mark-10 Corporation has been an innovator in the Force and Torque measurement fields since 1979. We strive to achieve 100% customer satisfaction through excellence in product design, manufacturing and customer support. In addition to our standard line of products we can provide modifications and custom designs for OEM applications. Our engineering team is eager to satisfy any special requirements. Please contact us for further information or suggestions for improvement.



We make a measurable difference in force and torque measurement

Mark-10 Corporation

11 Dixon Avenue
Copiague, NY 11726 USA
1-888-MARK-TEN
Tel: 631-842-9200
Fax: 631-842-9201
Internet: www.mark-10.com
Email: info@mark-10.com