



SMART FORCE AND TORQUE SENSORS

User's Guide

MARK-10®

Thank you...

Thank you for purchasing a Mark-10 Plug & Test™ remote sensor, designed for use with a Mark-10 model 5i or 3i force/torque indicator.

With proper usage, we are confident that you will get many years of great service with this product. Mark-10 sensors are ruggedly built for many years of service in laboratory and industrial environments.



This User's Guide provides setup, safety, and operation instructions for each individual sensor series. Instructions for using models 5i and 3i indicators are available in their respective user's guides. For additional information or answers to your questions, please do not hesitate to contact us. Our technical support and engineering teams are eager to assist you.

Before use, each person who is to use Mark-10 sensors and indicators should be fully trained in appropriate operation and safety procedures.

TABLE OF CONTENTS

OVERVIEW	2
SAFETY / PROPER USAGE	3
MECHANICAL SETUP	4
SERIES R01 FORCE SENSORS	5
SERIES R02 FORCE SENSORS	6
SERIES R03 FORCE SENSORS	7
SERIES R04 FORCE SENSORS	8
SERIES R05 FORCE SENSORS	9
SERIES R50 TORQUE SENSORS	10
SERIES R51 TORQUE SENSORS	11
SERIES R52 TORQUE SENSORS	12
SERIES R53 TORQUE SENSORS	13
SERIES R54 TORQUE SENSORS	14

1 OVERVIEW

1.1 General Overview

Several series of Plug & Test™ sensors are available to accommodate numerous force and torque measurement requirements – from 0.25 to 10,000 lbF (1 N to 50 kN) of force, and from 10 ozFin to 5,000 lbFin (7 Ncm to 550 Nm) of torque. These sensors can be handheld or mounted to a fixture or test stand for more sophisticated testing requirements.

Plug & Test™ sensors are used with Mark-10 5i and 3i indicators. They may be disconnected from one indicator and connected to another without the need for re-calibration or re-configuration. All such data is saved within a PCB located inside the smart connector.

The model number, serial number, and capacity of the sensor are identified in the rectangular label located on the Plug & Test™ connector. The model and serial numbers are also identified in the **Information** screen of the indicator. Refer to the indicator user's guides for more information.

1.2 Accuracy and Resolution

When evaluating the accuracy of a sensor, the system accuracy must be calculated by also taking into consideration the indicator accuracy, as follows:

Indicator Model	Accuracy
5i	±0.1% of full scale ±1 digit
3i	±0.2% of full scale ±1 digit

“±1 digit” refers to the least significant digit shown on the indicator display. This is equivalent to one increment of resolution. The resolution may be different for some sensors depending on whether a 5i or 3i indicator is being used. For example, a Series R01 force sensor will display finer resolution when connected to a 5i indicator than when connected to a 3i indicator. Resolution information is shown in the following pages for each sensor series.

The total system accuracy can be calculated by adding the sensor accuracy, indicator accuracy, and one count of resolution. Refer to the following examples:

Example 1

Model MR01-100 sensor with Model M5i Indicator

MR01-100 ±0.15% of full scale	+	M5i ±0.1% of full scale ±1 digit	=	Total ±0.25% of full scale ±1 digit
---	---	---	---	--

This translates into a fixed error of as high as:
 $0.25\% \times 100 \text{ lbF} = 0.25 \text{ lbF} + 0.05 \text{ lbF} = 0.30 \text{ lbF}$

Example 2

Model MR50-50Z sensor with Model M3i Indicator

MR50-50Z ±0.35% of full scale	+	M3i ±0.2% of full scale ±1 digit	=	Total ±0.55% of full scale ±1 digit
---	---	---	---	--

This translates into a fixed error of as high as:
 $0.55\% \times 50 \text{ ozFin} = 0.275 \text{ ozFin} + 0.02 \text{ ozFin} = 0.295 \text{ ozFin}$

Because accuracy is defined as a *percentage of full scale*, the fixed error is possible anywhere on the scale from 0 to the capacity. As such, this value represents an increasingly large error as *percentage of reading* towards the low end of the scale. It is, therefore, recommended that a sensor is selected with capacity as close as possible to the expected load.

2 SAFETY / PROPER USAGE

Read through the following safety instructions thoroughly before using a sensor:

1. Note the sensor's capacity before use and ensure that the capacity is not exceeded. Producing a load greater than the indicated safe overload value can damage the sensor. An overload can occur whether the sensor's indicator is powered on or off.
2. In order to extend the life of the sensor, avoid repetitive shock and impact loading.
3. When moving the sensor to another location, never lift from the cable or strain relief. This can cause damage to the sensor. Always lift the sensor housing itself.
4. Always ensure that load is applied axially with respect to the sensor.
5. Ensure that the sensor is kept away from water or any other electrically conductive liquids at all times.
6. The sensor and indicator should be serviced by a trained technician only. AC power must be disconnected and the indicator must be powered off before the housing is opened.
7. Always consider the characteristics of the sample being tested before initiating a test. A risk assessment should be carried out beforehand to ensure that all safety measures have been addressed and implemented.
8. Typical materials able to be tested include many manufactured items, such as springs, electronic components, fasteners, caps, films, mechanical assemblies, and many others. Items that should not be used with the sensor include potentially flammable substances or products, items that can shatter in an unsafe manner, and any other components that can present an exceedingly hazardous situation when acted upon by a force. Always wear eye and face protection when testing, especially in aforementioned hazardous cases. Extra bodily protection should be worn if a destructive failure of a test sample is possible.
9. In aforementioned hazardous situations, it is strongly recommended that a machine guarding system be employed to protect the operator and others in the vicinity from shards or debris.
10. Sensors have threaded holes or chucks, designed for the mounting of grips, fixtures, or attachments. If any such accessories are used, ensure they are mounted firmly to prevent a potential safety risk to the operator and others in the vicinity. If using an accessory from a supplier other than Mark-10, ensure that it is constructed of suitably rugged materials and components. Similar precautions should be taken when mounting the sensor to a test stand, work bench, or other piece of equipment.

3 MECHANICAL SETUP

The Plug & Test™ connector must be inserted into the receptacle of the 5i or 3i indicator with the side marked "Plug & Test™ Technology" facing up (see Fig. 3.1). When fully inserted, the connector will lock into place with a "click".



Fig. 3.1
Appropriate orientation of Plug & Test™ connector.

To release the connector, press both buttons on either side of the indicator housing to release the sensor (see Fig. 3.2). Pull the connector completely out of the indicator by holding the curved aluminum section. **DO NOT** pull on the cable or strain relief.



Fig. 3.2
Press both buttons on either side of the indicator housing to release the Plug & Test™ connector.

4 SERIES R01 FORCE SENSORS



4.1 Unpacking and Assembly

Carefully remove the sensor from the box. No assembly is required.

4.2 Overview

Tension and compression force may be applied to the surfaces with threaded holes. Attachments may be threaded into these holes. These holes also allow for mounting as required.

4.3 Specifications

Accuracy:	±0.15% of full scale
Safe overload:	150% of full scale
Operating temperature:	40°F – 110°F [5°C – 45°C]
Operating humidity:	96% max. (non-condensating)
Weight:	1.9 to 3.0 lb [0.9 to 1.4 kg], depending on model

4.4 Dimensions (in[mm])

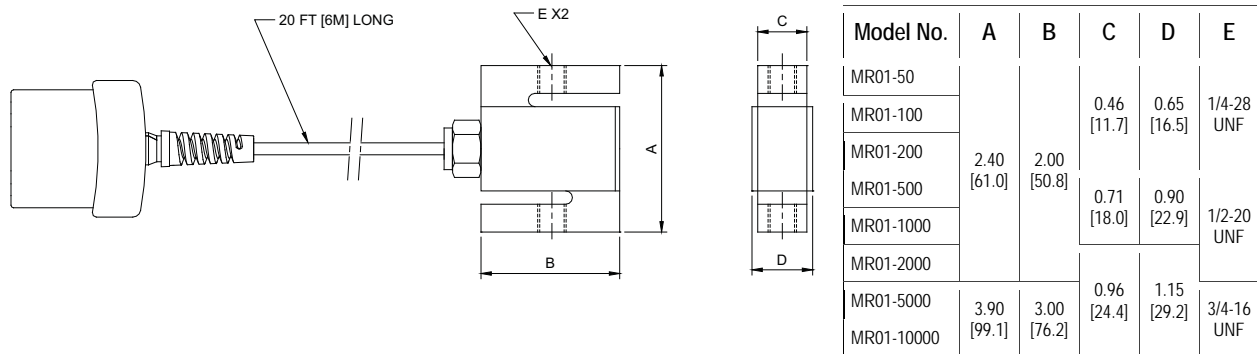

4.5 Capacity x Resolution

Model No.	With Model 5i Indicator						With Model 3i Indicator			
	lbF	ozF	gF	kgF	N	kN	lbF	kgF	N	kN
MR01-50	50 x 0.02	800 x 0.5	25000 x 10	25 x 0.01	250 x 0.1	-	50 x 0.05	25 x 0.02	250 x 0.2	-
MR01-100	100 x 0.05	1600 x 1	50000 x 20	50 x 0.02	500 x 0.2	-	100 x 0.1	50 x 0.05	500 x 0.5	-
MR01-200	200 x 0.1	3200 x 2	-	100 x 0.05	1000 x 0.5	1 x 0.0005	200 x 0.2	100 x 0.1	1000 x 1	-
MR01-500	500 x 0.2	8000 x 5	-	250 x 0.1	2500 x 1	2.5 x 0.001	500 x 0.5	250 x 0.2	2500 x 2	-
MR01-1000	1000 x 0.5	16000 x 10	-	500 x 0.2	5000 x 2	5 x 0.002	1000 x 1	500 x 0.5	5000 x 5	-
MR01-2000	2000 x 1	32000 x 20	-	1000 x 0.5	10000 x 5	10 x 0.005	2000 x 2	1000 x 1	10000 x 10	-
MR01-5000	5000 x 2	-	-	2500 x 1	25000 x 10	25 x 0.01	5000 x 5	2500 x 2	-	25 x 0.02
MR01-10000	10000 x 5	-	-	5000 x 2	50000 x 25	50 x 0.02	10000 x 10	5000 x 5	-	50 x 0.05

5 SERIES R02 FORCE SENSORS



5.1 Unpacking and Assembly

Carefully remove the sensor from the box. No assembly is required.

5.2 Overview

Compression force may be applied to the button in the center of the top surface of the sensor (visible in the picture above). **DO NOT** apply load to the cover on the underside of the sensor. Threaded holes are supplied to permit mounting to various surfaces.

5.3 Specifications

Accuracy:	±0.5% of full scale
Safe overload:	150% of full scale
Operating temperature:	40°F – 110°F [5°C – 45°C]
Operating humidity:	96% max. (non-condensating)
Weight:	MR02-100 - MR02-2000: 0.3 lb [0.1 kg] MR02-5000 - MR02-10000: 0.5 lb [0.2 kg]

5.4 Dimensions (in[mm])

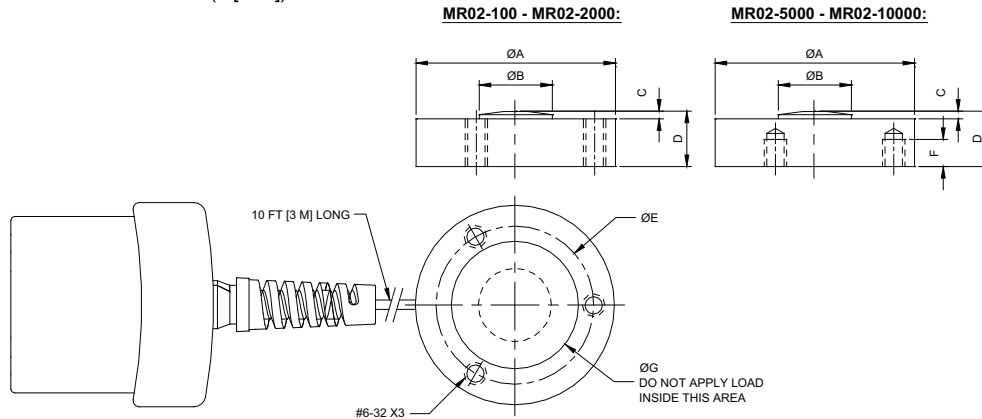

Model	ØA	ØB	C	D	ØE	F	ØG
MR02-100 – MR02-2000	1.23 [31.3]	0.32 [8.1]	0.05 [1.3]	0.39 [9.9]	1.0 [25.4]	-	0.83 [21.1]
MR02-5000 – MR02-10000	1.48 [37.6]	0.43 [10.9]	0.07 [1.8]	0.62 [15.8]	1.25 [31.8]	0.25 [6.4]	1.08 [27.4]

5.5 Capacity x Resolution

Model No.	With Model 5i Indicator						With Model 3i Indicator			
	lbF	ozF	gF	kgF	N	kN	lbF	kgF	N	kN
MR02-100	100 x 0.05	1600 x 1	50000 x 20	50 x 0.02	500 x 0.2	-	100 x 0.1	50 x 0.05	500 x 0.5	-
MR02-200	200 x 0.1	3200 x 2	-	100 x 0.05	1000 x 0.5	1 x 0.0005	200 x 0.2	100 x 0.1	1000 x 1	-
MR02-500	500 x 0.2	8000 x 5	-	250 x 0.1	2500 x 1	2.5 x 0.001	500 x 0.5	250 x 0.2	2500 x 2	-
MR02-1000	1000 x 0.5	16000 x 10	-	500 x 0.2	5000 x 2	5 x 0.002	1000 x 1	500 x 0.5	5000 x 5	-
MR02-2000	2000 x 1	32000 x 20	-	1000 x 0.5	10000 x 5	10 x 0.005	2000 x 2	1000 x 1	10000 x 10	-
MR02-5000	5000 x 2	-	-	2500 x 1	25000 x 10	25 x 0.01	5000 x 5	2500 x 2	-	25 x 0.02
MR02-10000	10000 x 5	-	-	5000 x 2	50000 x 25	50 x 0.02	10000 x 10	5000 x 5	-	50 x 0.05

6 SERIES R03 FORCE SENSORS



6.1 Unpacking and Assembly

Carefully remove the sensor from the box. Extra care should be taken for very low capacity models. No assembly is required.

6.2 Overview

Tension and compression force may be applied to the threaded holes in the load cell shaft and opposite flat surface. Attachments may be threaded into these holes. **Finger-tighten only**. These holes also allow for mounting as required.

6.3 Specifications

Accuracy:	±0.15% of full scale
Safe overload:	MR03-025 – MR03-2: 200% of full scale MR03-5 – MR03-100: 150% of full scale
Operating temperature:	40°F – 110°F [5°C – 45°C]
Operating humidity:	96% max. (non-condensating)
Weight:	0.4 lb [0.2 kg]

6.4 Dimensions (in[mm])

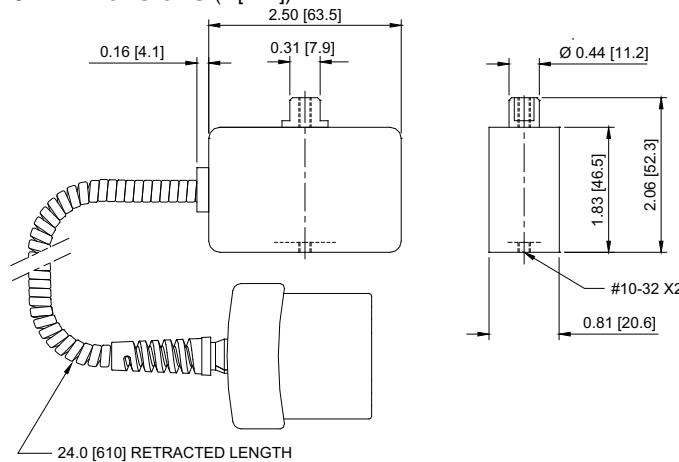

6.5 Capacity x Resolution

Model No.	With Model 5i Indicator						With Model 3i Indicator			
	lbF	ozF	gF	kgF	N	mN	lbF	gF	kgF	N
MR03-025	0.25 x 0.0001	4 x 0.002	100 x 0.05	-	1 x 0.0005	1000 x 0.5	0.25 x 0.0002	100 x 0.1	-	1 x 0.001
MR03-05	0.5 x 0.0002	8 x 0.005	250 x 0.1	-	2.5 x 0.001	2500 x 1	0.5 x 0.0005	250 x 0.2	-	2.5 x 0.002
MR03-2	2 x 0.001	32 x 0.02	1000 x 0.5	1 x 0.0005	10 x 0.005	-	2 x 0.002	-	1 x 0.001	10 x 0.01
MR03-5	5 x 0.002	80 x 0.05	2500 x 1	2.5 x 0.001	25 x 0.01	-	5 x 0.005	-	2.5 x 0.002	25 x 0.02
MR03-10	10 x 0.005	160 x 0.1	5000 x 2	5 x 0.002	50 x 0.02	-	10 x 0.01	-	5 x 0.005	50 x 0.05
MR03-20	20 x 0.01	320 x 0.2	10000 x 5	10 x 0.005	100 x 0.05	-	20 x 0.02	-	10 x 0.01	100 x 0.1
MR03-50	50 x 0.02	800 x 0.5	25000 x 10	25 x 0.01	250 x 0.1	-	50 x 0.05	-	25 x 0.02	250 x 0.2
MR03-100	100 x 0.05	1600 x 1	50000 x 20	50 x 0.02	500 x 0.2	-	100 x 0.1	-	50 x 0.05	500 x 0.5

7 SERIES R04 FORCE SENSORS



7.1 Unpacking and Assembly

Carefully remove the sensor from the box. Extra care should be taken for very low capacity models. No assembly is required.

7.2 Overview

Tension and compression force may be applied to the surfaces with threaded holes. Attachments may be threaded into these holes.

Finger-tighten only. These holes also allow for mounting as required.

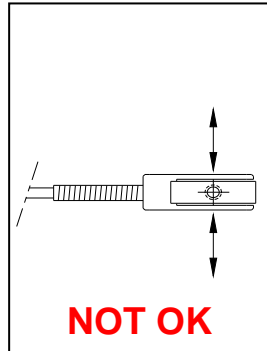
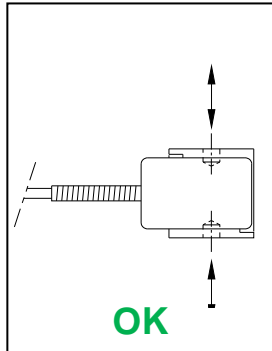

7.3 Specifications

Accuracy:	±0.2% of full scale
Safe overload:	200% of full scale
Operating temperature:	40°F – 110°F [5°C – 45°C]
Operating humidity:	96% max. (non-condensating)
Weight:	0.015 lb [0.007 kg]

7.4 Dimensions (in[mm])

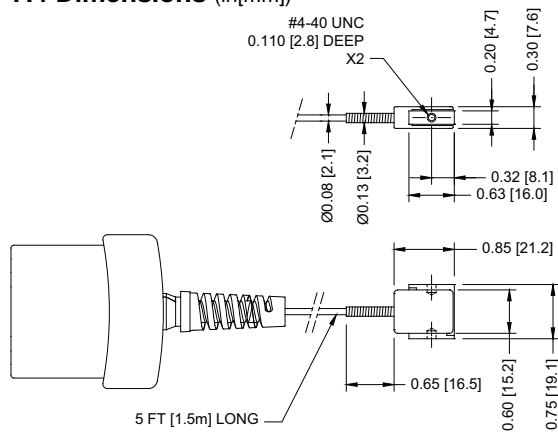

7.5 Capacity x Resolution

Model No.	With Model 5i Indicator						With Model 3i Indicator			
	lbF	ozF	gF	kgF	N	mN	lbF	gF	kgF	N
MR04-025	0.25 x 0.0001	4 x 0.002	100 x 0.05	-	1 x 0.0005	1000 x 0.5	0.25 x 0.0002	100 x 0.1	-	1 x 0.001
MR04-05	0.5 x 0.0002	8 x 0.005	250 x 0.1	-	2.5 x 0.001	2500 x 1	0.5 x 0.0005	250 x 0.2	-	2.5 x 0.002
MR04-2	2 x 0.001	32 x 0.02	1000 x 0.5	1 x 0.0005	10 x 0.005	-	2 x 0.002	-	1 x 0.001	10 x 0.01
MR04-5	5 x 0.002	80 x 0.05	1000 x 0.5	2.5 x 0.001	25 x 0.01	-	5 x 0.005	-	2.5 x 0.002	25 x 0.02
MR04-10	10 x 0.005	160 x 0.1	5000 x 2	5 x 0.002	50 x 0.02	-	10 x 0.01	-	5 x 0.005	50 x 0.05
MR04-20	20 x 0.01	320 x 0.2	10000 x 5	10 x 0.005	100 x 0.05	-	20 x 0.02	-	10 x 0.01	100 x 0.1
MR04-50	50 x 0.02	800 x 0.5	25000 x 10	25 x 0.01	250 x 0.1	-	50 x 0.05	-	25 x 0.02	250 x 0.2
MR04-100	100 x 0.05	1600 x 1	50000 x 20	50 x 0.02	500 x 0.2	-	100 x 0.1	-	50 x 0.05	500 x 0.5

8 SERIES R05 FORCE SENSORS



8.1 Unpacking and Assembly

Carefully remove the sensor from the box. No assembly is required.

8.2 Overview

Designed for pull and push testing. Firmly grip the handles when producing tension or compression force. Force may be applied to the surface with threaded hole. Attachments may be threaded into these holes. **Finger-tighten only.**

8.3 Specifications

Accuracy: $\pm 0.15\%$ of full scale
 Safe overload: 150% of full scale
 Operating temperature: 40°F – 110°F [5°C – 45°C]
 Operating humidity: 96% max. (non-condensating)
 Weight: 2 lb [0.9 kg]

8.4 Dimensions (in[mm])

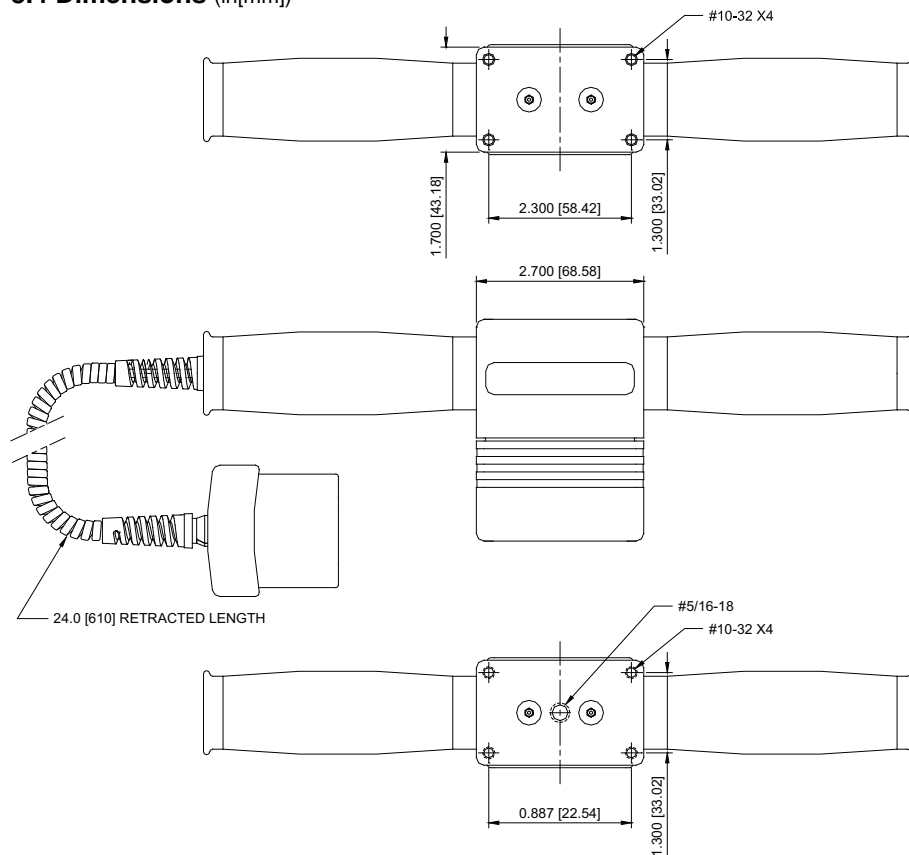

8.5 Capacity x Resolution

Model No.	With Model 5i Indicator					With Model 3i Indicator		
	lbF	ozF	kgF	N	kN	lbF	kgF	N
MR05-500	500 x 0.2	8000 x 5	250 x 0.1	2500 x 1	2.5 x 0.001	500 x 0.5	250 x 0.2	2500 x 2

9 SERIES R50 TORQUE SENSORS



9.1 Unpacking and Assembly

Carefully remove the sensor from the box. For models MR50-10Z, MR50-20Z, and MR50-50Z, remove the protective tubing inserted around the chuck. Save it for future transportation needs. No assembly is required.

9.2 Overview

Designed for clockwise and counter-clockwise torque testing. The sensor may be handheld or mounted to a test stand, fixture, or other equipment.

Bits or fixtures may be placed in the chuck, although extra care should be taken when handling low capacity models.

9.3 Specifications

Accuracy:	±0.35% of full scale
Safe overload:	MR50-10Z - MR50-50Z: 300% of full scale
	MR50-12 - MR50-100: 150% of full scale
Chuck opening range:	MR50-10Z - MR50-50Z: 0.062 - 0.375 in [1.6 - 9.5 mm]
	MR50-12 - MR50-100: 0.078 - 0.5 in [2.0 - 12.7 mm]
Operating temperature:	40°F – 110°F [5°C – 45°C]
Operating humidity:	96% max. (non-condensating)
Weight:	From 1.4 lb [0.6 kg]

9.4 Dimensions (in[mm])

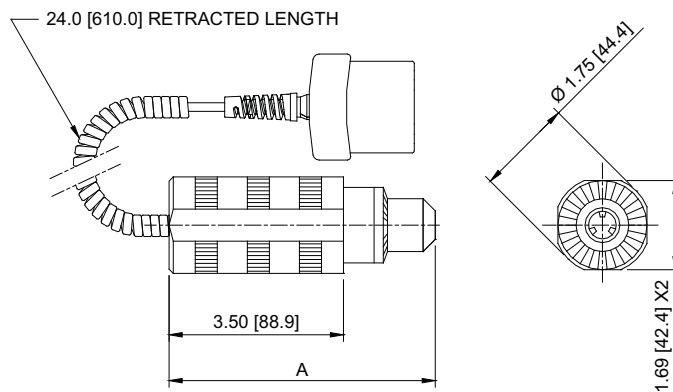

Model No.	A
MR50-10Z - MR50-50Z	4.82 [122.4]
MR50-12 - MR50-100	5.19 [131.8]

9.5 Capacity x Resolution

Model No.	With Model 5i indicator								With Model 3i indicator			
	ozFin	lbFin	lbFft	gFcm	kgFmm	Nmm	Ncm	Nm	ozFin	lbFin	kgFmm	Ncm
MR50-10Z	10 x 0.005	-	-	700 x 0.5	7 x 0.005	70 x 0.05	7 x 0.005	-	10 x 0.01	-	7 x 0.005	7 x 0.005
MR50-20Z	20 x 0.01	-	-	1400 x 1	14 x 0.01	140 x 0.1	14 x 0.01	-	20 x 0.02	-	14 x 0.01	14 x 0.01
MR50-50Z	50 x 0.02	-	-	3600 x 2	36 x 0.02	350 x 0.2	35 x 0.02	-	50 x 0.05	-	36 x 0.05	35 x 0.05
MR50-12	-	12 x 0.005	1 x 0.0005	-	140 x 0.1	-	135 x 0.1	1.35 x 0.001	-	12 x 0.01	140 x 0.1	135 x 0.1
MR50-50	-	50 x 0.02	4 x 0.002	-	580 x 0.5	-	570 x 0.5	5.7 x 0.005	-	50 x 0.05	580 x 0.5	570 x 0.5
MR50-100	-	100 x 0.05	8 x 0.005	-	1150 x 0.5	-	1150 x 0.5	11.5 x 0.005	-	100 x 0.1	1150 x 1	1150 x 1

10 SERIES R51 TORQUE SENSORS



10.1 Unpacking and Assembly

Carefully remove the sensor from the box. Series R51 sensors are available with three interchangeable chuck attachments and bit holder. To attach the chuck or bit holder, align the pin located on the end of the sensor body with the hole located on the attachment (see Fig. 10.1). Thread the ring onto the sensor body to keep the attachment in place.



Fig. 10.1
The attachment and main sensor body mate with a pin and threaded ring.

10.2 Overview

Designed for clockwise and counter-clockwise torque testing. The sensor may be handheld or mounted to a test stand, fixture, or other equipment. Bits or fixtures may be placed in the chuck, although extra care should be taken when handling low capacity models.

10.3 Specifications

Accuracy: $\pm 0.35\%$ of full scale
 Safe overload: MR50-10Z - MR50-50Z: 300% of full scale
 MR50-12 - MR50-100: 150% of full scale
 Chuck opening range: MR50-10Z - MR50-50Z: 0.062 - 0.375 in [1.6 - 9.5 mm]
 MR50-12 - MR50-100: 0.078 - 0.5 in [2.0 - 12.7 mm]
 Operating temperature: 40°F – 110°F [5°C – 45°C]
 Operating humidity: 96% max. (non-condensating)
 Weight: From 1.4 lb [0.6 kg]

10.4 Dimensions (in[mm])

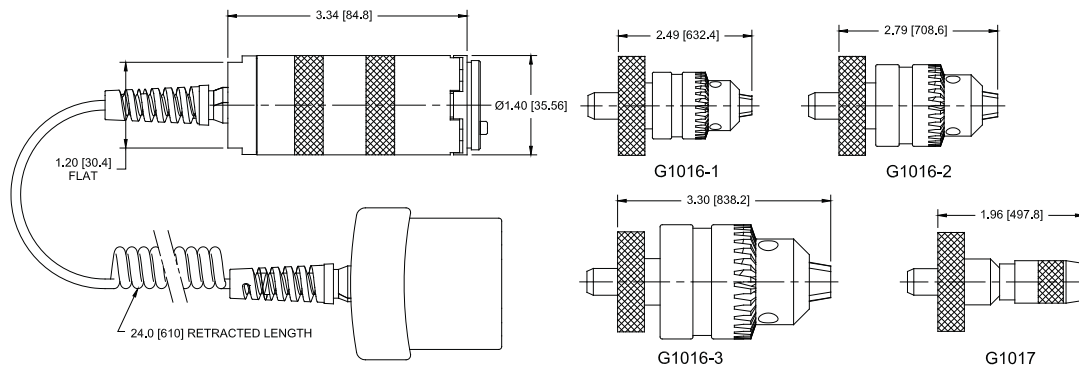

10.5 Capacity x Resolution

Model No.	With Model 5i indicator								With Model 3i indicator			
	ozFin	lbFin	lbFft	gFcm	kgFmm	Nmm	Ncm	Nm	ozFin	lbFin	kgFmm	Ncm
MR51-10Z	10 x 0.005	-	-	700 x 0.5	7 x 0.005	70 x 0.05	7 x 0.005	-	10 x 0.01	-	7 x 0.005	7 x 0.005
MR51-20Z	20 x 0.01	-	-	1400 x 1	14 x 0.01	140 x 0.1	14 x 0.01	-	20 x 0.02	-	14 x 0.01	14 x 0.01
MR51-50Z	50 x 0.02	-	-	3600 x 2	36 x 0.02	350 x 0.2	35 x 0.02	-	50 x 0.05	-	36 x 0.05	35 x 0.05
MR51-12	-	12 x 0.005	1 x 0.0005	-	140 x 0.1	-	135 x 0.1	1.35 x 0.001	-	12 x 0.01	140 x 0.1	135 x 0.1
MR51-50	-	50 x 0.02	4 x 0.002	-	580 x 0.5	-	570 x 0.5	5.7 x 0.005	-	50 x 0.05	580 x 0.5	570 x 0.5
MR51-100	-	100 x 0.05	8 x 0.005	-	1150 x 0.5	-	1150 x 0.5	11.5 x 0.005	-	100 x 0.1	1150 x 1	1150 x 1

12 SERIES R53 TORQUE SENSORS



12.1 Unpacking and Assembly

Carefully remove the sensor from the box. Install the four posts in the desired positions on the sliders. If alternative gripping fixtures were purchased, install them using the supplied hardware.

12.2 Overview

Designed for clockwise and counter-clockwise bottle cap torque testing. Turning the knob moves the sliders along the length of the screw to engage to disengage the sample. The posts or alternative gripping fixtures secure the sample while the cap is twisted by hand. The sensor contains threaded holes on the underside of the base for bench mounting.

12.3 Specifications

Accuracy: ±0.5% of full scale
 Safe overload: MR53-10Z - MR53-50Z: 300% of full scale / MR53-12 - MR53-100: 150% of full scale
 Operating temperature: 40°F – 110°F [5°C – 45°C]
 Operating humidity: 96% max. (non-condensating)
 Weight: MR53-10Z - MR53-50Z: 2.2 lb [1.0 kg] / MR53-12 - MR53-100: 5.4 lb [2.5 kg]

12.4 Dimensions (in[mm])

MR53-10Z - MR53-50Z:

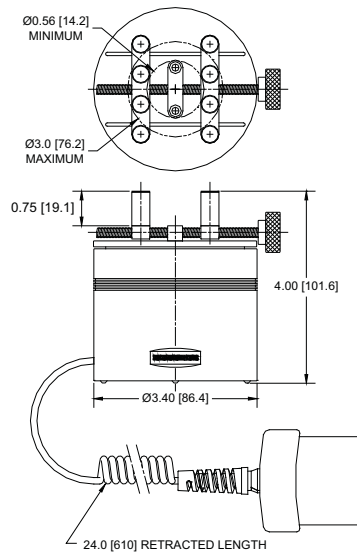

MR53-12 - MR53-100:

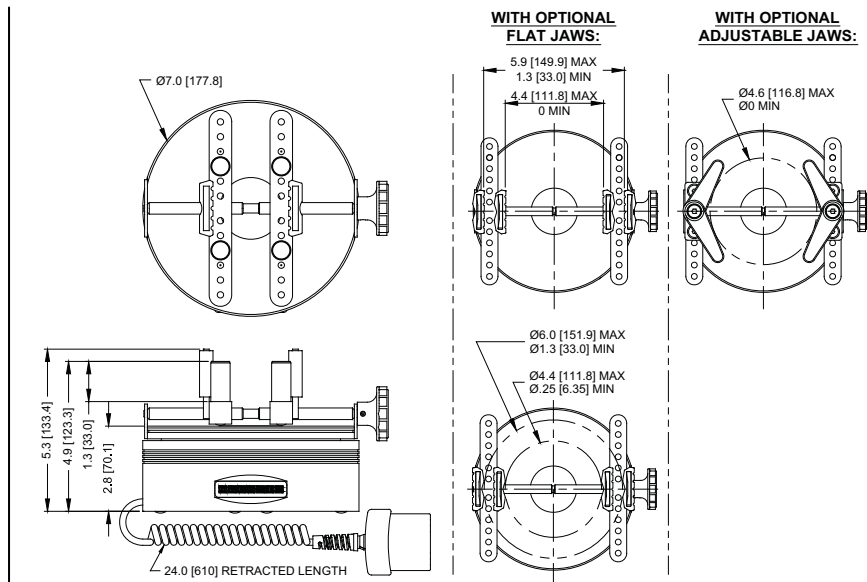

12.5 Capacity x Resolution

Model No.	With Model 5i indicator								With Model 3i indicator			
	ozFin	lbFin	lbFft	gFcm	kgFmm	Nmm	Ncm	Nm	ozFin	lbFin	kgFmm	Ncm
MR53-10Z	10 x 0.01	-	-	700 x 0.5	7 x 0.005	70 x 0.05	7 x 0.005	-	10 x 0.01	-	7 x 0.005	7 x 0.005
MR53-20Z	20 x 0.02	-	-	1400 x 1	14 x 0.01	140 x 0.1	14 x 0.01	-	20 x 0.02	-	14 x 0.01	14 x 0.01
MR53-50Z	50 x 0.05	-	-	3600 x 5	36 x 0.05	350 x 0.5	35 x 0.05	-	50 x 0.05	-	36 x 0.05	35 x 0.05
MR53-12	-	12 x 0.01	1 x 0.001	-	140 x 0.1	-	135 x 0.1	1.35 x 0.001	-	12 x 0.01	140 x 0.1	135 x 0.1
MR53-50	-	50 x 0.05	4 x 0.005	-	580 x 0.5	-	570 x 0.5	5.7 x 0.005	-	50 x 0.05	580 x 0.5	570 x 0.5
MR53-100	-	100 x 0.1	8 x 0.01	-	1150 x 1	-	1150 x 1	11.5 x 0.01	-	100 x 0.1	1150 x 1	1150 x 1

13 SERIES R54 TORQUE SENSORS



13.1 Unpacking and Assembly

Carefully remove the sensor from the box. No assembly is required.

13.2 Overview

Designed for clockwise and counter-clockwise torque testing. Square drives at both ends of the sensor permit inline testing or mounting to a test stand or other equipment.

13.3 Specifications

Accuracy: $\pm 0.6\%$ of full scale
 Safe overload: 150% of full scale
 Operating temperature: 40°F – 110°F [5°C – 45°C]
 Operating humidity: 96% max. (non-condensating)
 Weight: 0.6 - 2.0 lb [0.3 - 0.9 kg], depending on model

13.4 Dimensions (in[mm])

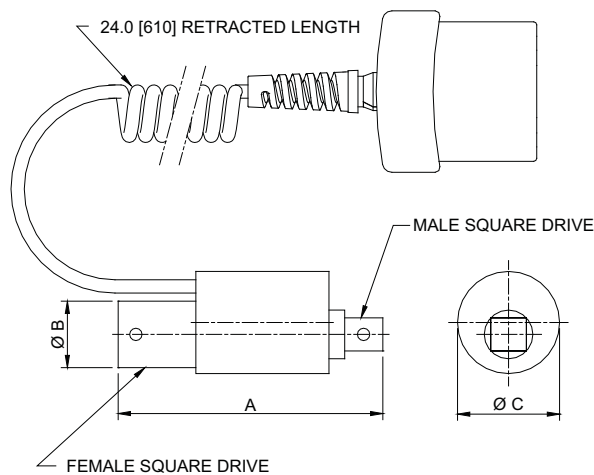

13.5 Capacity x Resolution

Model No.	With Model 5i indicator					With Model 3i indicator		
	lbFin	lbFft	kgFmm	Ncm	Nm	lbFin	kgFmm	Ncm
MR54-20	20 x 0.02	1.5 x 0.002	230 x 0.2	220 x 0.2	2 x 0.002	20 x 0.02	230 x 0.2	220 x 0.2
MR54-50	50 x 0.05	4 x 0.005	580 x 0.5	570 x 0.5	5.7 x 0.005	50 x 0.05	580 x 0.5	570 x 0.5
MR54-100	100 x 0.1	8 x 0.01	1150 x 1	1150 x 1	11.5 x 0.01	100 x 0.1	1150 x 1	1150 x 1
MR54-200	200 x 0.2	16 x 0.02	2300 x 2	2200 x 2	22 x 0.02	200 x 0.2	2300 x 2	2200 x 2
MR54-400	400 x 0.5	32 x 0.05	4600 x 5	4500 x 5	45 x 0.05	400 x 0.5	4600 x 5	4500 x 5
MR54-1000	1000 x 1	80 x 0.1	11500 x 10	11000 x 10	110 x 0.1	1000 x 1	11500 x 10	11000 x 10
MR54-5000	5000 x 5	400 x 0.5	55 x 0.05 kgFm	55000 x 50	550 x 0.5	5000 x 5	55 x 0.05 kgFm	550 x 0.5 Nm



Mark-10 Corporation has been an innovator in the force and torque measurement fields since 1979. We strive to achieve 100% customer satisfaction through excellence in product design, manufacturing and customer support. In addition to our standard line of products we can provide modifications and custom designs for OEM applications. Our engineering team is eager to satisfy any special requirements. Please contact us for further information or suggestions for improvement.



We make a measurable difference in force and torque measurement

Mark-10 Corporation

11 Dixon Avenue
Copiague, NY 11726 USA
1-888-MARK-TEN
Tel: 631-842-9200
Fax: 631-842-9201
Internet: www.mark-10.com
E-mail: info@mark-10.com