

Series **STE**

---

WRENCH EXTENSION TORQUE SENSORS

# Reference Guide

**MARK-10**®

## GENERAL

Carefully remove the sensor from its packaging and inspect for any damage.

The sensor is shipped ready to use. No assembly is required.

Series STE torque sensors work in conjunction with the BGI force/torque indicator for instantaneous, average, and peak torque measurements. Simply plug the 15-pin connector into the external sensor connector on the indicator.

Please note that all calibration data and menu selections programmed and saved during setup with the BGI are saved within the sensor. While this allows for interchangeability, each sensor must be programmed separately.

In order to extend the life of your unit, avoid repetitive shock and impact loading.

## DIMENSIONS AND SPECIFICATIONS in [mm]

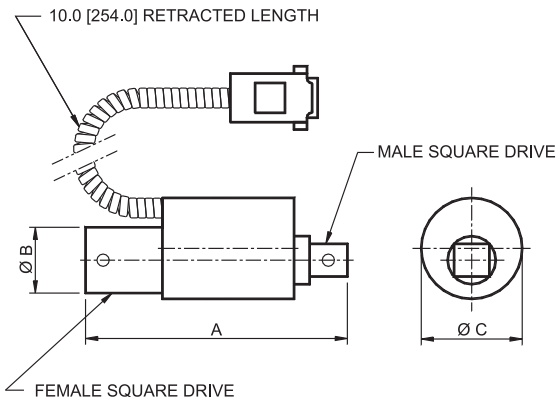

Model	Capacity x Resolution	A	ØB	ØC	Drive Size
STE20	20 x 0.02 lbin, 230 x 0.2 kgFmm, 220 x 0.2 Ncm	1.88 [47.8]	0.56 [14.2]	1.00 [25.4]	1/4"
STE50	50 x 0.05 lbin, 580 x 0.5 kgFmm, 570 x 0.5 Ncm				
STE100	100 x 0.1 lbin, 1150 x 1 kgFmm, 1150 x 1 Ncm				
STE200	200 x 0.2 lbin, 2300 x 2 kgFmm, 2200 x 2 Ncm	3.00 [76.2]	0.73 [18.5]	1.12 [28.6]	3/8"
STE400	400 x 0.5 lbin, 4600 x 5 kgFmm, 4500 x 5 Ncm				
STE1000	1000 x 1 lbin, 11500 x 10 kgFmm, 11000 x 10 Ncm	3.50 [88.9]	0.98 [24.9]	1.25 [31.8]	1/2"
STE5000	5000 x 5 lbin, 55 x 0.05 kgFm, 550 x 0.5 Nm	5.00 [127.0]	1.48 [37.6]	2.0 [50.8]	3/4"

Accuracy:  $\pm 0.6\%$  FS + BGI

Operating conditions:

Temperature: 40°F - 110°F [5°C - 45°C]

Humidity: 96% max. (no condensation)

Safe overload % of capacity: 150

## WARRANTY

Mark-10 Corporation expressly warrants to its buyer for three (3) years from the date of delivery that the goods sold are free from defects in workmanship and materials. Mark-10 Corporation will, at its option, repair or replace or refund the purchase price of goods found to be defective. This remedy shall be the buyer's sole and exclusive remedy. Any modification, abuse, exposure to corrosive environment or use other than intended will void this warranty. This warranty is in lieu of all other warranties, including implied warranties of merchantability and fitness for an intended purpose. In no event shall Mark-10 Corporation be liable for any incidental and consequential damages in connection with goods sold or any part thereof.

# OTHER MARK-10 PRODUCTS

A full line of force and torque measurement products and related items, including force gauges, torque gauges, force and torque test stands, sensors, grips, software, and more.



**MARK-10**

*We make a measurable difference in force and torque measurement*

**Mark-10 Corporation**

11 Dixon Avenue  
Copiague, NY 11726  
888-MARK-TEN  
Tel: 631-842-9200  
Fax: 631-842-9201  
Internet: [www.mark-10.com](http://www.mark-10.com)  
E-mail: [info@mark-10.com](mailto:info@mark-10.com)

